

**INTERNATIONAL JOURNAL OF ENGINEERING SCIENCES & RESEARCH
TECHNOLOGY**
**NEW INNOVATION IN ELECTRONIC MEASURING SYSTEM USING LVDT
SENSOR****Shruti D. Taksande*, Vijay Bagdi**

* Department of Computer Science & Engineering Abha Gaikwad-Patil College of Engineering, Nagpur

DOI: 10.5281/zenodo.55544

ABSTRACT

In industry field, common A/D converter chips are widely used for low-speed analog data acquisition. Most of common A/D converter chips are not fit for the requirements of high-speed vary analog signal. This paper presents a high-speed data acquisition system based on LVDT. Design, simulation, implementation and testing of an inductive displacement sensor based on a Linear Variable Differential Transformer (LVDT) controlled by a single chip electronic module with 8 bit RISC microcontroller. LVDT device is widely used systems for measuring physical quantities like displacement, force or pressure. The design is based on PAC-1.0 card is proposed for LVDT sensor detection and realized the high-speed digital data acquisition of multichannel sensor digital signals in the method of software polling mode. This paper aims to present an experimental device, which measures the displacement of inner diameter and outer diameter. This displacement is measured with a very high degree of accuracy, by means of inductive probe. The probe and its associated electronics system convert the displacement into a proportional voltage. The measured results of application indicate that the measurement precision can reach 0.1 μm , and 1 μm . This system has good commonality as well as extensibility.

KEYWORDS: LVDT sensor.**INTRODUCTION**

Now days the demand of digital measuring machine increasing day by day in most of business enterprises because Measuring the inner diameter and outer diameter with digital measuring machine is user friendly with variety of various applications. This research paper shows the design and implementation of high resolution advanced digital measuring scale design based on 12-bit ADC along with fully featured embedded system.

As the measuring of articles is an essential part of modern life, there is a constant need for knowing the exact inner diameter and outer diameter of bearing and many items, e.g., for production, testing, etc. Consequently, the legal requirements of government bodies internationally are trying to maintain the same constant pace. In production, this means high accuracy and efficiency of measuring are also constantly high on the agenda. Continuation of this trend brings benefits for both the customer and the producer. That is, manufacturing efficiency is increased and hence profitability while package quality and quantity are assured to the customer's satisfaction. In the area of mass production, products are weighed using electronic measuring scale, that a package fast and accurately. In the mail sorting and grading machinery. In the practice, the micro-controllers using general algorithms cannot meet higher accuracy.

The trends of measuring scale designers' increases towards higher accuracy and lower cost production. It will increase demand of high-performance analog signal processing at low cost.

PROJECT OVERVIEW

In general, MEG (Measuring Electronic Gauges) is a multipurpose gauging system designed especially for the inspection of various parameters of a component like ID, OD, HEIGHT, WIDTH and OVALITY etc.

This dedicated Instrument provides facilities like static and dynamic mode measurements, Inch and Metric scale measurements, high and low Gain settings, storage of UPPER and LOWER set limits with a Tolerance Status Multicolor Indicator, Hold function to hold the current reading, Least Count setting for better resolution and accuracy, Inner and Outer diameter measurements and above all, MEG is equipped with a serial communication utility based on RS 232 standard connected with PC.

MEG (Measuring Electronic Gauges) has a single channel and is compatible probe.

In this proposed work, we have presented the new measuring electronic gauges which is based on LVDT. We propose to measure the height, width and ovality of the instrument. A Tri-colored display indicates status of the measurement value. Green indicates measurement is within range, Red indicates measurement is not within the range and Yellow stands for measurement is not within the range but rework is possible. Depending upon the Upper and Lower tolerances you set in the limit setting. Corresponding relay contacts are ON and OFF. The relay "1" is ON when reading is greater than USL, the relay "2" is ON when reading is in between USL and LSL, and the relay "3" is ON when reading is lesser than LSL. The Linear Variable Differential Transformer (LVDT) is a displacement measuring instrument and is not a strain-based sensor.

The LVDT models closely the ideal Zero-order displacement sensor structure at low frequency, where the output is a direct and linear function of the input. The LVDT is a variable-reluctance device, where a primary center coil establishes a magnetic flux that is coupled through a mobile armature to a symmetrically-wound secondary coil on either side of the primary.

MEG is equipped with serial communication facility, which allows the user to transmit the current reading to an external device like PC. RS232 serial communication standard is used for the purpose of data transmission.

D) Requirements for carrying out Project: -

- Personal Computer.
- LVDT
- Microcontroller
- Relay Card
- 7-Segment DISPLAY
- Power Supply

Components used

In analog section IC:

1. IC723
2. IC311
3. IC380
4. IC347

In Digital Section

1. AVR Microcontroller
2. MAX 332

Keypad:

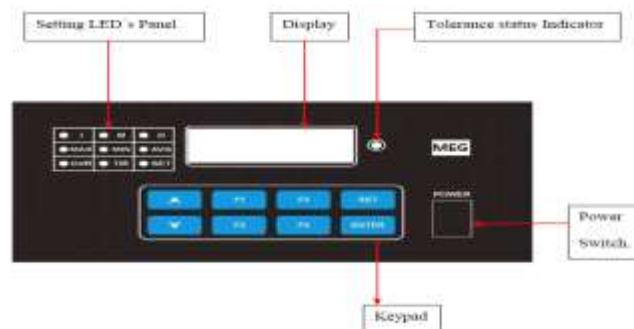

8 keys have been provided to configure various parameters of instrument.

1. UP KEY.
2. DOWN KEY.
3. F1: - Function one for master one.
4. F2: - function two for master two.
5. F3: - Function three.
6. F4: - Function four.
7. SET: - Set key provided to enter in to settings mode.
8. ENTER: - Enter key provide

BLOCK DIAGRAM

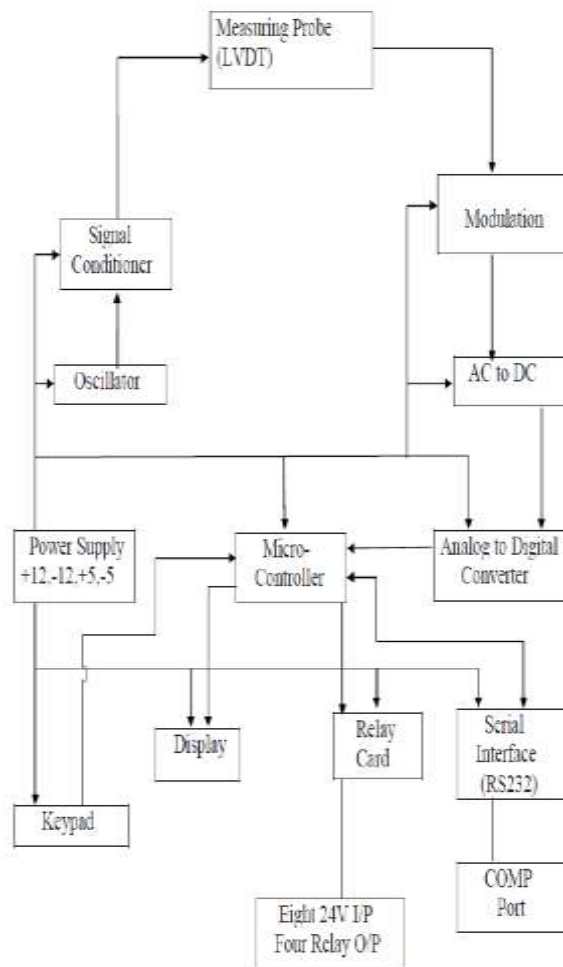

Fig.1 Block Diagram of Measuring Electronic Gauging System

Block Diagram Description

The measuring probe is connected to the probe connector (5 pin Audio). The analog input signal from probe is amplified, demodulated, filtered and converted in to a DC signal, proportional to a measured dimension.

This analog signal is converted in to a digital signal using a analog to digital converter IC. This signal is processed and displayed on a display unit using a processor. A TTL to RS232 trans receiver is used for communication with an external device.

Power Supply

AC input requirement: 230 V, 50Hz.

Fuse Rating: 2A.

Transformer Rating: Primary 230V

Secondary 9-0-9 V, 15-0-15 V AC.

MEG 1.1 operates on 230 V, 50Hz single-phase power supply. The Input AC power is fed to primary of transformer through a fuse and power ON/OFF switch. The output Voltage of secondary is rectified, filtered and fed to regulator IC's.

The analog part (including oscillator, audio amplifier, signal conditioner etc.) requires +12 and -12 Volts. The digital part requires +5 and -5 Volts. Four voltage regulators 7805,7905,7812 and 7912 are used to provide output voltages of +5, -5, +12 and -12 respectively.

Oscillator and Audio Amplifier

The Oscillator section generates the excitation required to drive the transducer. A transistorized RC phase shift oscillator is used generate oscillations. Its O/P is buffered by an audio amplifier IC and fed to the primary of driver transformer. Secondary O/P of transformer is adjusted to 4V p-p, 10 kHz AC and given to Transducer (probe). Linear electronic oscillator circuits, which generate a sinusoidal output signal, are composed of an amplifier and a frequency selective element, a filter. An oscillator circuit which uses an RC network, a combination of resistors and capacitors, for its frequency selective part.

Signal Conditioner

Signal conditioning means manipulating an analog signal in such a way that it meets the requirements of the next stage for further processing. Many applications require environment or structural measurements, such as temperature and vibration, from sensors. These sensors, in turn, require signal conditioning before a data acquisition device can effectively and accurately measure the signal. Key signal conditioning technologies provide distinct enhancements to both the performance and accuracy of data acquisition systems.

Modulation

In electronics and telecommunications, **modulation** is the process of varying one or more properties of a periodic waveform, called the carrier signal, with a **modulating** signal that typically contains information to be transmitted. Common modulation methods include:

- Amplitude modulation (AM), in which the voltage applied to the carrier is varied over time
- Frequency modulation (FM), in which the frequency of the carrier waveform is varied in small but meaningful amounts
- Phase modulation (PM), in which the natural flow of the alternating current waveform is delayed temporarily.

Ac to Dc:

Both **AC** and **DC** describe types of current flow in a circuit. In direct current (DC), the electric charge (current) only flows in one direction. Steady magnetism along the wire. Electric charge in alternating current (AC), on the other hand, changes direction periodically. Rotating magnet along the wire.

ADC and Processor:

The variable O/P DC signal of signal conditioner is fed to Analog to Digital converter IC. ADC IC converts analog signal in to 12 bit binary signal. The processor accepts this digital signal on its data bus, along with this it takes care of keypad, display and serial communication routines. An analog-to-digital converter (ADC, A/D, or A to D) is a device that converts a continuous physical quantity (usually voltage) to a digital number that represents the quantity's amplitude. The conversion involves quantization of the input, so it necessarily introduces a small amount of error. Instead of doing a single conversion, an ADC often performs the conversions ("samples" the input) periodically. The result is a sequence of digital values that have been converted from a continuous-time and continuous-amplitude analog signal to a discrete-time and discrete-amplitude digital signal.

LVDT Sensor

The linear variable differential transformer (LVDT) (also called just a differential transformer, linear variable displacement transformer, or linear variable displacement transducer) is a type of electrical transformer used for measuring linear displacement (position). LVDTs are robust, absolute linear position/displacement transducers; inherently frictionless, they have a virtually infinite cycle life when properly used. As AC operated LVDTs do not contain any electronics. The LVDT converts a position or linear displacement from a mechanical reference (zero, or null position) into a proportional electrical signal containing phase (for direction) and amplitude (for distance) information. The LVDT operation does not require an electrical contact between the moving part (probe or core assembly) and the coil assembly, but instead relies on electromagnetic coupling.

The Single-Channel Indicators can be used in conjunction with LVDTs to make up a comprehensive, reliable, measurement system. The combination can be applied to a wide variety of demanding measurement applications, such as in process gaging in automated assembly machinery, differential measurements in thickness gaging, and other measurements. Utilize the units' programmable set points, relays and you have an economical solution when you need control functions for direct measurements in smaller automated systems. The 4-digit alphanumeric 7-segment displays provide easy to follow setup prompts for all LVDT parameters using the intuitive scrolling text configuration menus.

Most cartridge gage heads operate on a linear variable differential transducer (LVDT) principle. The LVDT is an electromechanical device consisting of a primary coil, flanked by two secondary coils connected in series. All coils surround a movable, magnetic core—the spindle—which provides a path for magnetic flux linking the coils.

Microcontroller

A microcontroller (sometimes abbreviated μC , uC or MCU) is a small computer on a single integrated circuit containing a processor core, memory, and programmable input/output peripherals. Program memory in the form of NOR flash or OTP ROM is also often included on chip, as well as a typically small amount of RAM. Microcontrollers are designed for embedded applications.

Keypad

A keypad is a set of buttons arranged in a block or "pad" which usually bear digits, symbols and usually a complete set of alphabetical letters. Keypad is used to make changes manually in device.

Display

We have used 7-segment display to show the measurement reading. It changes color for output accordingly. We have used Tri-color display so, it would be easy for operators. In this we will use Green, Red and Orange color for simplicity purpose.

Relay

A relay is an electrically operated switch. Many relays use an electromagnet to mechanically operate a switch, but other operating principles are also used, such as solid-state relays. Relays are used where it is necessary to control a circuit by a low-power signal (with complete electrical isolation between control and controlled circuits), or where several circuits must be controlled by one signal.

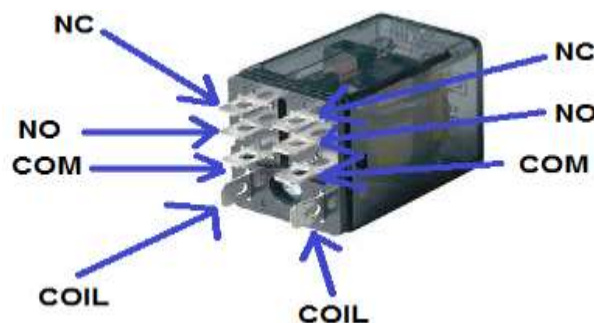

Fig.2 12v Relay DODT

COIL-This the is the COIL terminal. These are the terminals where you apply voltage to in order to give power to the coils (which then will close the switch). Polarity does not matter. One side gets positive voltage and the other side gets negative voltage.

NO- This is Normally Open switch. This is the terminal where you connect the device that you want the relay to power, when the relay is powered, meaning when the COIL receives sufficient voltage. The device connected to NO will be off when the relay has on power.

NC- This is the Normally Closed Switch. This is the terminal where you connect the device that you want powered when the relay receives no power. The device connected to NC will be on when the relay has no power and will turn off when the relay receives power.

COM- This is the common of the relay. If the relay is powered and the switch is closed, COM and NO have continuity. If the relay isn't powered and the switch is open, COM and NC have continuity. This is the terminal of the relay where you connect the first part of your circuit to.

LAYOUT AND DESIGN OF THE SET-UP

We developed the system made of three different parts. We designed the circuit for the hardware which will be used to collect data from the inductive linear displacement sensor and generate a output of digital data. Signal conditioning circuit was used to filter the sensor signal to the ADC of core microcontroller. We also developed the firmware using the COMP port which is a framework for the AVR microcontroller as the core processing unit of our system. A user interface software in the PC side also been developed written it Embedded C programming language.

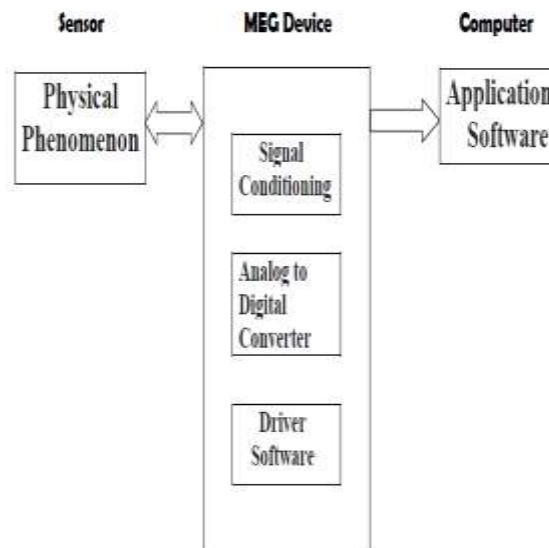

Fig.3A Schematic of the Design architecture

Hardware Design

The Hardware consists of a signal conditioning unit and a microcontroller. The linear displacement of LVDT is represented as voltage from +2 to -2 volt as output from the sensor. Operational amplifier and voltage level converter IC was used to condition the signal from the sensor and convert it to 0 volt to 5 volt range accordingly. Then we need analog to digital converter to make our analog data to take digital form. After that we need to send the digital data to the bus of PC side interface. We chose AVR microcontroller as it serves the dual purpose of analog to digital conversion and interfacing with the PC with its built In COMP port. Therefore, the hardware construction was done by making the circuit of signal conditioning unit and microcontroller based unit.

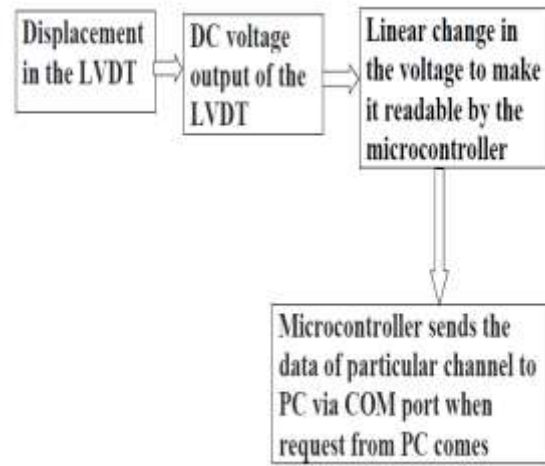

Fig.4 A Circuit Diagram of the Design architecture

In GUI (Graphical User Interface of the software))the COM port number of the hardware connected to the PC should be entered in the proper text-box.

RESULT AND DISCUSSION

Range:

The system is designed for the range of -1999 to +1999 microns. But the range can be increased by choosing ADC with high number of bits. The range of the system depends on the transducer.

Resolution:

The resolution of the ADC used is 10 mV when V_{ref} is 2.5V as it is a 12-bit ADC. So with a change of 10 mV in the input of the ADC, the digital output of the system changes by 1 micron. Therefore the resolution of the system is 1μ .

Accuracy:

The output of the designed system is found almost linearly proportional to the input displacement. There are a number of factors affecting the accuracy of the system such as unsterilized input AC voltage; the transducer may be non-linear, presence of noise in the circuit components. Though accuracy of the system is somewhat reduced but according to its design it gives quite satisfactory results. Also by using 16-bit ADC, the resolution and accuracy of the system can be increased to a great extent.

CONCLUSION AND FUTURE WORK

In the static Measuring Electronic Gauging System conventional filtering method employed have limitation in improving the accuracy and in throughput rate. In this case, an alternative technique has been explored to find a solution. It will enable high measurement accuracy and good throughput rate of article measuring. By doing this work we also experienced that it is tough task to get good result with 12-bit ADC under much more noisy circumstances. Thus with the help of this it is possible to design very high precision enhanced measuring scale at low cost.

The displacement sensor is useful in various fields of engineering and testing. The described device is a substantially cheap structure for the displacement sensor. Therefore by proper finance and marketing, the device may be a potential replacement for present displacement sensors along with being much more cost-effective.

REFERENCES

- [1] "Application of LVDT sensor data acquisition system based on PCI-1716".JinhuiFan ; Coll. of Electron. Inf. & Control Eng., Beijing Univ. of Technol., Beijing, China ; SongminJia ; Wei Lu ; Zhihong Wang. Computer Science and Automation Engineering (CSAE), 2011 IEEE International Conference on (Volume:3)
- [2] "System on Chip Signal Conditioner for LVDT Sensors". Drumea, A. ; Dept. of Electron. Technol., Univ. "Politehnica" Bucharest ;Vasile, A. ; Comes, M. ; Blejan, M. Published in: Electronics Systemintegration Technology Conference, 2006. 1st (Volume:1)
- [3] "Modelling and simulation of an inductive displacement sensor for mechatronic systems Drumea".A. ; Dept. of Electron. Technol. & Reliability, Politeh. Univ. Bucharest, Bucharest, Romania ;Svasta, P. ; Blejan, M.Published in: Electronics Technology (ISSE), 2010 33rd International Spring Seminar on
- [4] "Capacitive Sensor Device for Measuring Loads on Bearings". Rasolofondraibe, L. ; Lab. of CReSTIC, Univ. of Reims-Champagne Ardenne, Reims, France ; Pottier, B. ; Marconnet, P. ; Chimentin, X. Published in: Sensors Journal, IEEE (Volume:12 , Issue: 6)
- [5] Design of LVDT Based Digital Weighing SystemPratikshaSarma1, P. K. Bordoloi2 Published in: International Journal of Electronics and Computer Science Engineering.
- [6] F. Yassa and S. Garverick, "A multichannel digital demodulator for LVDT/RVDT position sensor," IEEE J. Solid-State Circuits, vol. 25, no. 2, pp. 441–450, Apr. 2006
- [7] Low-Cost USB-Based Data-Logger for LVDT Sensor Md. Saiful Isla ; Md. Liakot Ali Published in the 2014 International Conference on Industrial Engineering and Operations Management Bali, Indonesia, January 7 – 9, 2014.
- [8] Lakkoju, N.K.; Gudla, S.; Mantravadi, B.S. (2011). AVR-USB DATA ACQUISITION. Electronics Computer Technology (ICECT), 2011 3rd . 1 (1), p35 – 39
- [9] Danisi, "Simulation of DC interfering magnetic field effects on the LHC collimators' LVDT positioning sensors," M.S. thesis, Dept. Electron. Eng., Univ. "Federico II", Naples, Italy, 2009.
- [10] G. Spiezia, R. Losito, M. Martino, A. Masi, and A. Pierno, "Automatic test bench for the measurement of the magnetic interference on LVDTs," in Proc. I2MTC, Austin, TX, May 2010, pp. 850–854.
- [11] Rashmi R, Mrs.RukminiDurgale, "The Novel of Embedded Based Digital Gauge," International Conference on Computing and Control Engineering (ICCCE 2012), 12 & 13 April, 2012.
- [12] (Webster1999) John G Webster, "The Measurement, Instrumentation, and Sensors Handbook". CRC Press with IEEE press, Boca Raton, Florida, 1999.
- [13] Prof. Kataria S. M., Prof. Vaghela V. B.—Design and Implementation of High Precision Advanced Weighing Machine with TFT Panel Department of Electronics and Communication, Sankalchand Patel College of Engineering.
- [14] http://www.macrosensors.com/ms-lvdt_faq-tutorial.html